

COLUMN ASSEMBLY AND INSTALLATION

COLUMN TYPE: RAISE & LOWER SPRING - FLANGEPLATE MOUNTED

WE STRONGLY RECOMMEND THAT THESE INSTRUCTIONS ARE READ CAREFULLY BEFORE ATTEMPTING TO INSTALL AND OPERATE THIS EQUIPMENT.

REFERENCE SHOULD ALSO BE MADE TO THE APPROPRIATE COUNTERBALANCE OPERATING INSTRUCTIONS WHICH ARE SUPPLIED WITH THE UNIT.

GENERAL

These columns have a wide variety of uses including amenity, railway and road lighting applications up to 8m in height, either post top or with a projection bracket.

Assembly on site is kept to a minimum. Ideally the foundation bolts should be cast in to the concrete foundation 3 to 4 weeks prior to erection of the column to allow time to cure. Foundation block sizes for a variety of ground conditions can be supplied on request.

Columns are constructed from lengths of steel tube, to EN10210 grade S275 or S355, welded together to form the required mounting height. The column and foundation bolts are finished galvanised with small fasteners from stainless steel.

INSTALLATION

Reference should be made to the illustrations which follow the text.

NOTE: IT IS NOT POSSIBLE TO ATTACH A SPRING COUNTERBALANCE TO A COLUMN WHICH HAS BEEN INSTALLED WITH ITS SHAFT IN THE LOWERED POSITION. WE WOULD STRONGLY ADVISE THAT SUCH COLUMNS ARE INSTALLED IN THE SAME MANNER AS A CONVENTIONAL COLUMN.

- i) Before commencement of installation examine the items and ensure that there are no missing or damaged parts. The following items of equipment will be required (not Abacus supply). Timber supports and packers, a mobile crane for erection, typically 1.0 tonne and a torque multiplier and wrench.
- ii) Assemble the bracket to the top shaft section and secure with the screws provided. It should be noted that the power supply cable can be installed during assembly or, if preferred after assembly is completed, but prior to fixing the bracket.
- iii) While the column is on the ground, and referring to the counterbalance operating instructions, ensure that the column is in its locked position and that the locking device is in place.
- iv) The holding down bolts are each fitted with two nuts and washers. The upper nut and washer and template should be removed. The threads should be examined for any damage and rectified using a die nut if necessary. The nuts should be set in level plane using a steel bar and spirit level across each opposing pair of nuts.
- v) Using a crane lift the column and place carefully over the foundation bolts and on to the lower set of nuts. Ensure the direction of lowering is as required and that the column will clear any obstructions. Secure the column with the upper set of retaining nuts and washers and roughly plumb up the base section.

INSTALLATION

vi) After completion of the installation check for vertical alignment. This can be adjusted using the upper and lower nuts as necessary. Once the alignment is satisfactory all bolts should be tightened to the required torque setting.

If the gap below the flange is to be grouted it is essential that adequate provision is made for ventilation and drainage of any water collecting inside the base.

vii) The column can then be commissioned.

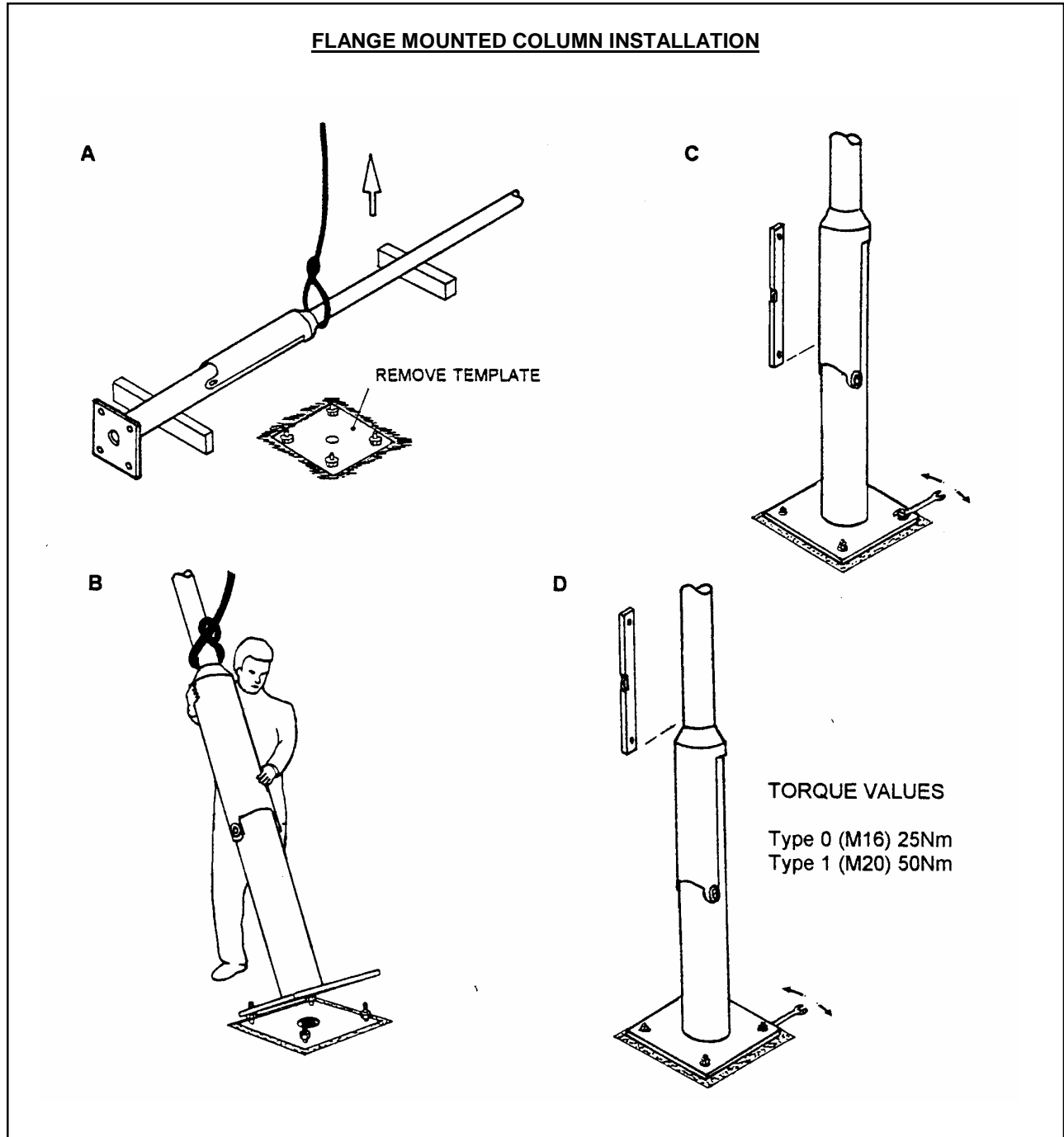

FOR FURTHER ADVICE CONTACT THE ABACUS TECHNICAL DEPARTMENT

UK and World-wide Patents

ABACUS LIGHTING LIMITED. Sutton - in - Ashfield, Nottinghamshire, NG17 5FT, England. Tel: (+44) 01623 51111 Fax: (+44) 01623 552133

COLUMN ASSEMBLY AND INSTALLATION

COLUMN TYPE: RAISE & LOWER SPRING - ROOT MOUNTED

WE STRONGLY RECOMMEND THAT THESE INSTRUCTIONS ARE READ CAREFULLY BEFORE ATTEMPTING TO INSTALL AND OPERATE THIS EQUIPMENT.

REFERENCE SHOULD ALSO BE MADE TO THE APPROPRIATE COUNTERBALANCE OPERATING INSTRUCTIONS WHICH ARE SUPPLIED WITH THE UNIT.

GENERAL

These columns have a wide variety of uses including amenity, railway and road lighting applications up to 8m in height, either post top or with a projection bracket.

Assembly on site is kept to a minimum. The foundation hole should be excavated to the size and depth stated in the manufactures data sheet, appropriate to the ground conditions on site.

Columns are constructed from lengths of steel tube, to EN10210 grade S275 or S355, welded together to form the required mounting height. The column is finished galvanised as standard with small fasteners from stainless steel.

INSTALLATION

Reference should be made to the illustrations which follow the text.

NOTE: IT IS NOT POSSIBLE TO ATTACH A SPRING COUNTERBALANCE TO A COLUMN WHICH HAS BEEN INSTALLED WITH ITS SHAFT IN THE LOWERED POSITION. WE WOULD STRONGLY ADVISE THAT SUCH COLUMNS ARE INSTALLED IN THE SAME MANNER AS A CONVENTIONAL COLUMN.

i) Before commencement of installation examine the items and ensure that there are no missing or damaged parts. The following items of equipment will be required (not Abacus supply). Timber supports and packers, a mobile crane for erection, typically 1.0 tonne and a lump hammer and adjustable spanners.

ii) Assemble the bracket to the top shaft section and secure with the screws provided. It should be noted that the power supply cable can be installed during assembly or, if preferred after assembly is completed, but prior to fixing the bracket.

iii) While the column is on the ground, and referring to the counterbalance operating instructions, ensure that the column is in its locked position and that the locking device is in place.

iv) Using a crane lift the column and place the root section in the previously prepared foundation hole. Ensure that the direction of lowering is as required and that the column will clear any obstructions. Appropriate allowance should be made if future resurfacing is envisaged. It should be noted that the minimum distances from ground level to the pivot centre line are as follows:-

CAM TYPE	=	280mm
CAMLESS TYPE	=	310mm

Roughly 'plumb up' the base section and back fill the hole either with concrete or excavated material to just below the cable entry slot. All back filling using excavated material should be placed in 150mm thick layers and must be well compacted.

INSTALLATION

v) Chock the column using wooden wedges in the space between column and foundation sidewall. By adjusting these wedges accurately 'plumb up' the column using the shaft as the reference plane not the base section.

vi) Back fill the remaining hole with either concrete or excavated material and ram well in, removing wedges as encountered.

vii) A duct, equal in size to the cable entry slot, should be formed through the back fill material using a suitable pre formed lining tube to allow for the insertion of electric cables.

viii) Leave the column for a minimum of four days for any concrete to harden. The column can then be commissioned.

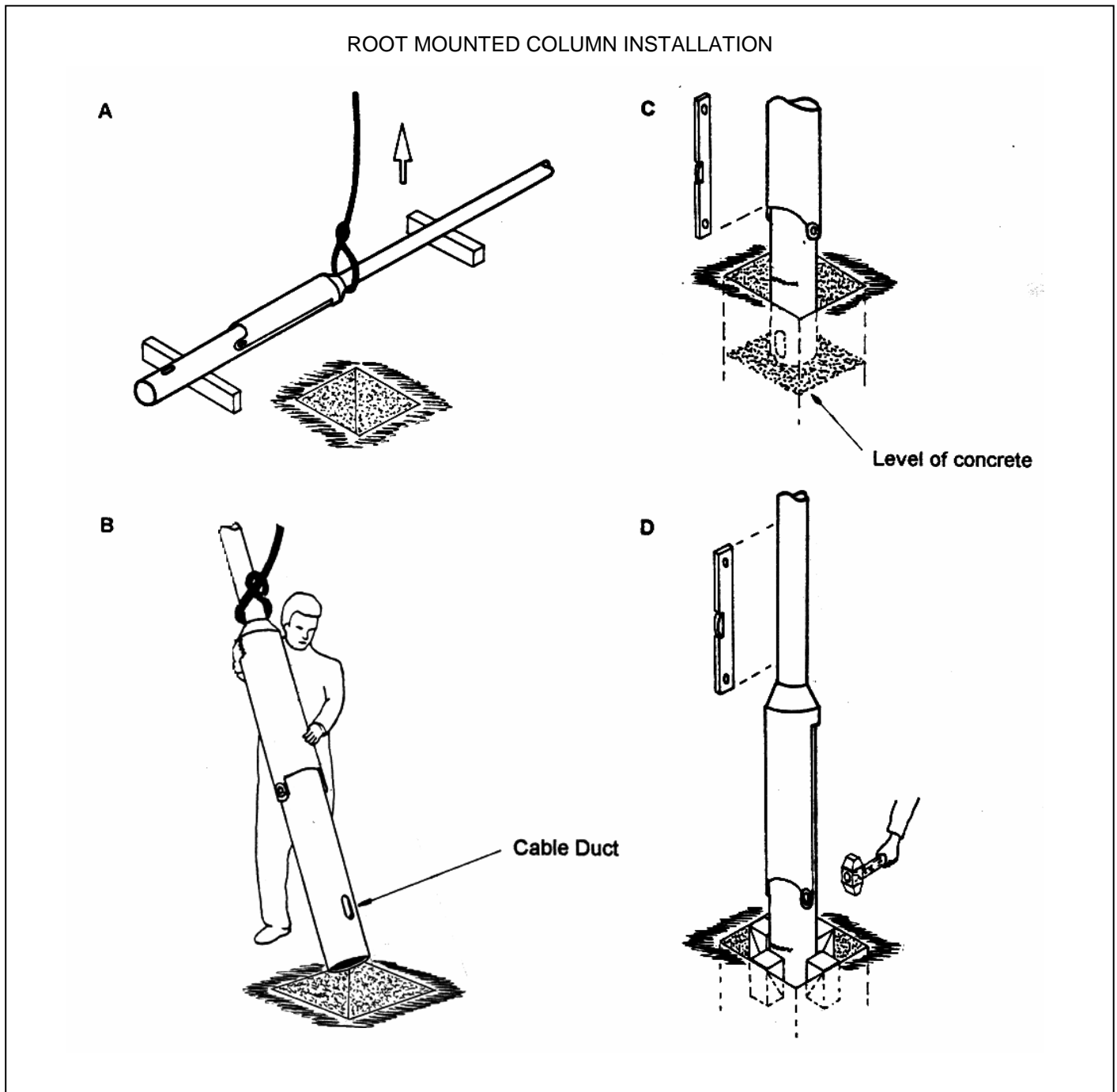

COLUMN ASSEMBLY AND INSTALLATION

COLUMN REF: RAISE & LOWER - Ø168RLS & Ø168RLH (CAM TYPE)

WE STRONGLY RECOMMEND THAT THIS CLEARANCE ZONE INFORMATION IS READ IN CONJUNCTION WITH THE INSTRUCTIONS FOR COLUMN ASSEMBLY, INSTALLATION AND COUNTERBALANCE OPERATION.

GENERAL

It is essential that the area around the base is kept clear of obstructions at all times to allow for the safe operation of mast and counterbalance. The illustration below gives details of the minimum clearance zone that is required around the column.

